

Water Industry Specification

*Water Industry Specifications and IGNs are also issued by:
UK Water Fittings Byelaws Scheme ISSN 0267-0313
and Process Systems Committee ISSN 0956-5132*

SPECIFICATION FOR TYPE A FLEXIBLE COUPLINGS FOR GRAVITY SEWERAGE AND DRAINAGE PIPES

FOREWORD

This specification has been prepared by WRc under the direction of the Sewers and Water Mains Committee to define the requirements for Type A flexible couplings for gravity sewerage and drainage pipes.

Further specifications may be prepared for flexible couplings that are outwith the scope of this specification.

The Type A coupling consists of a moulded elastomeric sleeve with two stainless steel clamping bands and a stainless steel shear band with the dimensions given in Table 1. The clamping bands enable the elastomeric sleeve to form a seal with the pipes to be joined. The shear band gives resistance to shear forces and imposed loads whilst allowing some flexibility to cater for ground settlement. Connections may be made between pipes of dissimilar sizes and materials. Where the difference in the outside diameter of the pipes exceeds 16mm, the connection may be made by using the appropriate bush with the coupling.

Adaptor couplings are available to joint pipes of significantly different diameters. These do not include a shear band and are excluded from this specification.

The couplings may be used for:

- (i) Repair of damaged pipeline components.
- (ii) Post connection of branches to existing sewers or drains by the "junction insertion" technique.
- (iii) Connecting pipes of different materials and/or diameters where there is no standard product.
- (iv) Jointing short/cut lengths of pipe.

For most applications, additional protection of the coupling is not required. Where the couplings are to be used in made up ground such as industrial fill, or where the ground or ground water contains significant levels of chloride ion, chlorine, the coupling manufacturer/supplier should be consulted.

Compliance with this specification does not itself confer immunity from legal obligations.

This specification does not purport to include all the necessary provisions of a contract. Users of this specification are responsible for its correct application.

Where reference is made to a British Standard or other specification, this shall be understood to refer equally to any other equivalent specification.

This specification requires that the manufacturer shall operate an acceptable quality system relating to the manufacture of couplings to this specification in compliance with BS5750: Part 2 (EN29002), which ensures that products claiming to comply with this specification consistently meet the required level of quality. Enquiries regarding the availability of third party certification should be addressed to an appropriate third party NACCB or equivalent accredited certification body or to WRc Swindon.

This specification calls for the use of substances and/or procedures that may be injurious to health if adequate precautions are not taken. It refers only to technical suitability and does not absolve the user from legal obligations relating to health and safety at any stage.

It has been assumed in the drafting of this specification that the execution of its provisions is entrusted to appropriately qualified and experienced people.

Information contained in this specification is given in good faith but neither the Foundation for Water Research, WSA nor WRc can accept any responsibility for actions taken as a result.

CONTENTS

FOREWORD

1. SCOPE
2. QUALITY ASSURANCE
3. MATERIALS



- 4. DESIGN
 - 4.1 General
 - 4.2 Dimensions and tolerances
 - 4.3 Worm drive units
 - 4.4 Spot welding
- 5. TYPE TESTS
- 6. QUALITY CONTROL TESTS
 - 6.1 Frequency of testing
- 7. TEST REQUIREMENTS
 - 7.1 Dimensional tests
 - 7.2 Strength tests for clamp band assembly
 - 7.3 Spot weld testing
 - 7.4 Coupling performance tests
- 8. MARKING
- 9. REFERENCES

APPENDICES

- A. Strength Test for Clamp Band Assembly
- B. Tensile Strength of Spot Welds
- C. Method of Determination of Joint Water Tightness
- D. Method of Test for the Resistance to Temperature

1. SCOPE

This document specifies the requirements for Type A flexible couplings of nominal size 100 - 600 inclusive, for gravity sewerage and drainage pipes. The couplings covered by this specification consist of an elastomeric sleeve with stainless steel clamping and shear bands with the dimensions given in Table 1.

The requirements include quality assurance, materials, design, type and quality control tests.

Adaptor bushes are included which may be used to facilitate connections between pipes of different outside diameters.

Couplings with dimensions outwith Table 1, couplings designed specifically to join pipes of significantly different diameters and couplings designed and supplied as part of a proprietary pipeline system are not covered by this specification.

2. QUALITY ASSURANCE

Manufacturers shall operate a quality system relating to this specification in compliance with BS 5750: Part 2 (EN29002).

3. MATERIALS

The elastomeric sleeve and adaptor bush shall comply with the performance requirements of Type D BS 2494: 1986. The minimum specified nominal hardness of the elastomer for both sleeves and bushes shall be 60 IRHD.

The bush shall not adversely affect the sealing performance of the coupling.

The material for the screw clamps shall be either not less than grade 304 S11 BS 970: Part 1: 1983, or not less than grade 304 S17 BS 3111: Part 2: 1979. Material for the shear and clamp bands shall be not less than grade 304 S11 cold rolled to 300 HV \pm 25 BS 1449: Part 2: 1983.

4. DESIGN

4.1 General

When fitted according to the manufacturer's instructions, the coupling shall not damage or distort the pipes to which it is connected.

All stainless steel parts shall be edge dressed and free from sharp edges to prevent injury to the installer and damage to the elastomeric sleeve.

4.2 Dimensions and tolerances

The inside diameter of the elastomeric sleeve and the inside diameter of the adaptor bush shall comply with class M3 fixed of BS 3734: 1978. The diameter shall be that stated by the manufacturer excluding any ribs or profiling.

NOTE: This does not relate to the range of sizes of pipes for which the coupling may be suitable but is a measure of the consistency of the manufacturing process.

Extruded elastomeric strip from which bushes and couplings sleeves may be fabricated shall comply in dimensional tolerance with Class E2 of BS 3734: 1978.

Table 1 – Minimum dimensions

Nominal coupling size	Min width of sleeve (mm)	Min thickness under clamping band (mm)	Min width of shear band (mm)	Min thickness of shear band (mm)
Up to 200	120	7.0	54	0.35
201 – 300	150	7.5	78	0.35
301 – 600	185	9.0	97	0.75

The coupling shall comply with the minimum dimensions stated in Table 1.

The width of the clamping bands shall not be less than 15mm and their thickness not less than 0.7mm.

4.3 Worm drive units

Worm drive units used in the construction of the shear band shall be of same design and specification as those of the clamp bands.

4.4 Spot welding

Spot welded assemblies for shear bands shall have a minimum of 3 welds that comply with the requirements of 7.3.

5. TYPE TESTS

The test requirements are specified in Table 2. These shall be carried out for the initial proving of the design and when significant changes are made to the design of the coupling or changes to the manufacturing method or materials.

6. QUALITY CONTROL TESTS

The test requirements are specified in Table 2 and shall be carried out to demonstrate the consistency of the product.

Table 2 – Test requirements

Test	Clause	Type test	Quality control
Dimensions	7.1	✓	✓
Strength of clamp band assembly	7.2	✓	✓
Spot welds on shear band	7.3	✓	✓
Coupling performance	7.4	✓	X

6.1 Frequency of testing

6.1.1 Dimensional tests

Frequency of sampling for dimensional tests shall be carried out in accordance with the requirements of BS 6001, inspection level S3 for attributes, or BS 6002 for variables at an AQL level equal or better than 2.5.

6.1.2 Strength test for clamp band assembly

Two clamp band assemblies from one coupling selected from within each of the size ranges in Table 3, shall be tested annually or when the source of supply is changed.

6.1.3 Spot weld testing

At the start of each manufacturing batch for each shear band thickness, the melt cross-section shall be measured by means of a sample weld in accordance with 7.3.

Annually, two samples from each gauge of shear band shall be selected and tested in accordance with Appendix B.

7. TEST REQUIREMENTS

7.1 Dimensional tests

7.1.1 Internal elastomeric sleeve diameter shall be checked, with the clamps removed, by measuring the external circumference around the clamp band position. The diameter is calculated by:

$$\text{Internal diameter} = \frac{\text{External circumference}}{\pi} - (2 \times \text{sleeve thickness})$$

7.1.2 Dimensions of elastomeric sleeves shall comply with 4.2.

7.1.3 Extruded bush strip and extruded section from which couplings are manufactured shall comply with 4.2.

7.1.4 The internal diameter of the adaptor bush shall be checked in three equi-spaced positions around the bush. The average of the results shall comply with 4.2.

7.1.5 The width and thickness of the clamp bands and shear band shall be checked at two points diametrically opposite each other. The values shall comply with 4.2.

7.2 Strength tests for clamp band assembly

The clamp band assembly shall withstand a minimum torque of 17Nm when tested in accordance with Appendix A. There shall be no visible damage or distortion of any part of the assembly.

7.3 Spot weld testing

The spot-welds for shear bands shall either have a minimum melt cross-section of 2mm when torsionally sheared or be stronger than the parent metal as demonstrated by the failure of the parent metal rather than the weld.

When tested in accordance with Appendix B the spot weld assembly shall withstand a minimum force of 6000N.

Table 3 – Designated size ranges

Nominal coupling size	Minimum angle of deflection (degrees)	Pipe material combinations	Test mode
100 – 200	3	Vit Clay to Vit Clay Ductile Iron to PVC-U Vit Clay to Ductile Iron	A B A
201 – 400	2	Vit Clay to Vit Clay Vit Clay to Ductile Iron Ductile Iron to PVC-U	A A B
401 – 600	1 ¾	Ductile Iron to PVC-U Concrete to Ductile Iron Concrete to Concrete	B A A

Table 4 – Test requirements

Test mode	Restrained pipe	Unrestrained pipe	Test combination
A	Rigid	Rigid	Vacuum and shear Vacuum and deflection Pressure and shear Pressure and deflection
B	Rigid	Flexible	Vacuum and diameter distortion Vacuum and deflection Pressure and diameter distortion Pressure and deflection

7.4 Coupling performance tests

The combinations of pipe materials in Table 3 shall be joined and tested using at least one coupling selected from within the designated size ranges.

Where adaptor bushes are supplied as part of the range, a minimum of one test per designated size range shall include at least one bush/coupling combination.

7.4.1 *Shear, deflection, diameter distortion tests*

The requirements for the test modes in Table 3 are given in Table 4 and the test methods are described in Appendix C. When tested in accordance with C3, C4 and C7, the pressure in the test assembly shall rise by less than 0.10 bar. There shall be no visible leakage of water when tested under hydrostatic pressure in accordance with C5, C6 and C8.

7.4.2 *Heat resistance*

The heat resistance of couplings up to 200mm internal diameter shall be tested as described in Appendix D for one size of a rigid/rigid pipe combination. The joint shall not leak during the test.

NOTE: If the joint leaks due to the failure of the test pipes, the test results shall be disregarded and the test repeated.

8. MARKING

The coupling shall be legibly and durably marked on the outside surface with the following information:-

- (a) The manufacturer's identification.
- (b) The number of this Water Industry Specification i.e. WIS No. 4-41-01. (The use of this mark is a claim by the manufacturer that the product has been manufactured in accordance with the requirements of this specification and the claim is his sole responsibility).
- (c) The nominal size.
- (d) The month of manufacture.

9. REFERENCES

This specification makes reference to the latest edition of the following publications (except where otherwise indicated), including all addenda and revisions.

- | | |
|--------|---|
| BS 970 | Specification for wrought steels for mechanical and allied engineering purposes.
Part 1 General inspection and |
|--------|---|

testing procedures and specific requirements for carbon, carbon manganese, alloy and stainless steels.

BS 1449	Steel plate, sheet and strip. Part 2 Specification for stainless and heat-resisting steel plate, sheet and strip.
BS 1610	Materials testing machines and force verification equipment. Part 1 Specification for the grading of the forces applied by materials testing machines.
BS 2494	Specification for elastomeric joint rings for pipework and pipelines.
BS 3111	Steel for cold forged fasteners and similar components. Part 2 Stainless steel.
BS 3734	Specification for dimensional tolerances of solid moulded and extruded rubber products.
BS 5750 (EN 29002)	Quality systems. Part 2 Specification for production and installation.
BS 6001	Sampling procedures for inspection by attributes. Part 1 Specification for sampling plans indexed by acceptable quality level (AQL) for lot-by-lot inspection.
BS 6002	Specification for sampling procedures and charts for inspection by variables for percent defective.

APPENDIX A – STRENGTH TEST FOR CLAMP BAND ASSEMBLY

A1 APPARATUS

A cylindrical former which will not distort under the applied load from the bands.

A torque wrench that complies with the accuracy requirement for grade 2.0 testing machines given in BS 1610: Part 1: 1985, capable of applying a torque of 17Nm.

A2 PROCEDURE

A2.1 The test band shall be placed on a former.

A2.2 The worm drive units shall be tightened with the aid of a torque wrench until an indicated torque of 17Nm is achieved.

A2.3 The bands shall be left for a minimum of 30 minutes and then loosened.

A2.4 The above procedure shall be repeated on the same bands, and the band assemblies visually inspected.

A3 TEST REPORT

The report shall include the following information:

- (a) Identification of the test sample (manufacturer, batch, size).
- (b) Results of visual inspection.
- (c) Date of test.

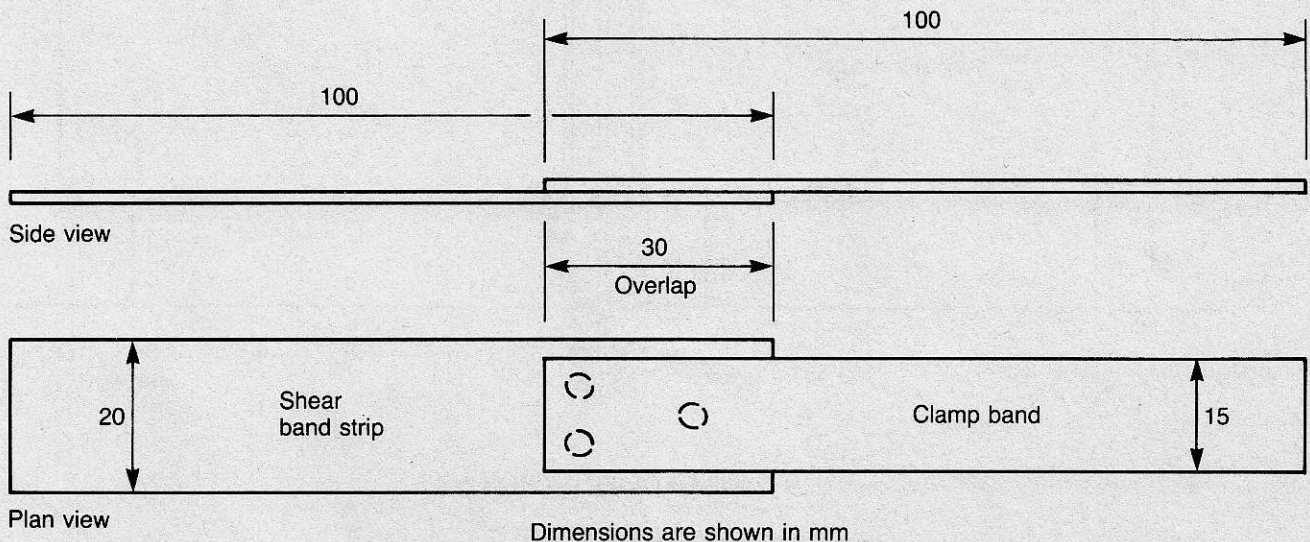

Figure 1 – Test sample for tensile strength of spot welds

APPENDIX B – TENSILE STRENGTH OF SPOT WELDS

B1 APPARATUS

Tensile testing machine that complies with the accuracy requirement for grade 1.0 testing machines given in BS 1610: Part 1: 1985.

B2 PROCEDURE

B2.1 The sample shall be prepared by welding a 100mm length of unperforated clamp band strip to a section of shear band strip cut 20mm wide x 100mm long with an overlap at the weld of 30mm as shown in Figure 1. The welding equipment, the welding conditions and the pattern of the welds shall be identical to that used in the normal production of shear band components.

B2.2 Extend the sample at a cross-head separation rate of 3mm/min until weld failure, and record the maximum tensile force.

B3 TEST REPORT

The report shall include the following information:

- (a) Identification of the test sample (manufacturer, batch, size).
- (b) Maximum tensile force at weld failure.
- (c) Date of test.

APPENDIX C – METHOD OF DETERMINATION OF JOINT WATER TIGHTNESS

C1 APPARATUS

The apparatus shall accommodate two pipes joined by a coupling and shall be capable of application of transverse load, angular deflection and partial vacuum or constant water pressure. The ends of the pipes remote from the coupling shall be sealed and the apparatus shall resist end thrust without otherwise supporting the pipes against the test vacuum or pressure.

The apparatus is shown schematically in Figure 2. The two pipes shall be axially aligned with an initial gap between pipe ends of $20\text{mm} \pm 3\text{mm}$. The pipe ends remote from the joint shall be restrained to prevent further longitudinal movement during the test.

One pipe shall be supported behind the coupling and the free end of the barrel and shall be restrained so as not to permit more than 5mm movement during the test. The second pipe shall have a minimum length of 850mm and be supported at the end of the barrel remote from the joint. The length of the support, measured parallel to the pipe axis, shall be nominally 150mm or $1/10$ of the nominal size of the pipe, whichever is the greater. The pipe shall be restrained at the support so as not to permit more than 5mm movement during the test.

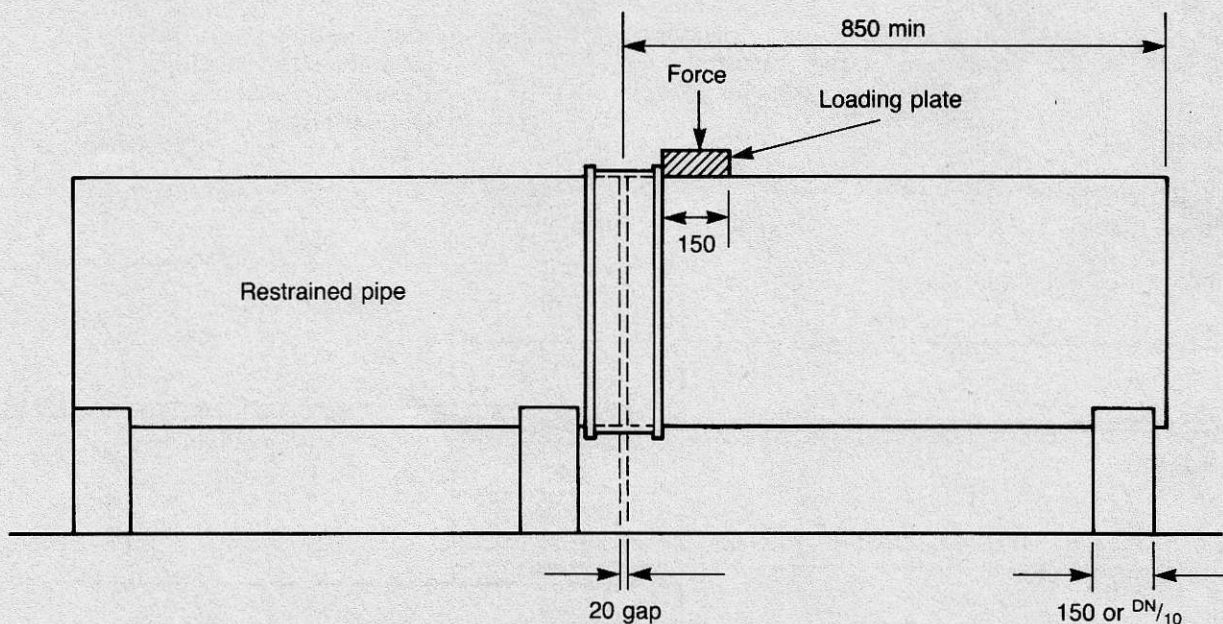

Dimensions are shown in mm

Figure 2 – Determination of joint water tightness

Place the coupling centrally over the gap between pipes and tighten all clamps in accordance with the manufacturer's instructions.

C3 VACUUM AND SHEAR TEST

C3.1 Apply a vertically downward force of 25N per millimetre of nominal size of pipe over a longitudinal distance of 150mm from the face of the coupling on the unrestrained pipe.

As an alternative, the force may be applied in a vertically upward direction provided the force is increased by the weight of the pipe.

C3.2 Evacuate the pipes to a pressure of -0.25 bar (0.75 bar absolute).

Isolate the test assembly from the vacuum source and measure the pressure within the test assembly after 15 minutes. Where one of the pipes is either vitreous clay or concrete and a pressure rise greater than 0.10 bar is obtained, coat the inside and outside of the pipe (except for the outside surface of the pipe covered by the coupling) with a proprietary sealer to prevent the ingress of air through the walls of the pipe; repeat the test.

C4 VACUUM AND DEFLECTION TEST

C4.1 Release the vacuum and shear force and realign the pipes.

C4.2 Deflect one pipe angularly with respect to the other by the amount shown in Table 3 with the fulcrum on the longitudinal axis of the pipes and within the coupling.

C4.3 Apply the procedure of C3.2.

C5 PRESSURE AND SHEAR TEST

C5.1 Align the pipes and fill with water at a temperature not exceeding 25°C, taking care to remove all air from the pipes before application of pressure.

C5.2 Apply the procedure of C3.1.

C5.3 Apply a hydrostatic pressure of 1 bar for a period of 5 minutes and examine the assembly for leakage.

C6 PRESSURE AND DEFLECTION TEST

C6.1 Release the pressure and shear load and align the pipes.

C6.2 Apply the procedure of C4.2.

C6.3 Apply the procedure of C5.3.

C7 VACUUM AND DIAMETER DISTORTION

C7.1 Apply vertical force to the top and bottom of the flexible pipe barrel over a longitudinal distance of 150mm from the face of the coupling so as to cause a deformation of 5% of the pipe outside diameter. The vertical force shall remain in place through the test.

C7.2 Apply the procedure of C3.2.

C8 PRESSURE AND DIAMETER DISTORTION

C8.1 Apply the procedure of C7.1

C8.2 Apply the procedure of C5.1.

C8.3 Apply the procedure of C5.3.

C9 REPORT

- (a) Identification of the coupling.
- (b) Identification of the test pipes (manufacturer, material, class and dimensions).
- (c) Record of pressures and times.
- (d) Leakage observations.
- (e) Date and place of test.

APPENDIX D – METHOD OF TEST FOR THE RESISTANCE TO TEMPERATURE

D1 APPARATUS

D1.1 Apparatus as described in C1.

D1.2 Equipment suitable for passing hot water at 70 – 75°C, measured at the discharge, through the test assembly.

D1.3 Equipment to continuously record the temperature of the water to an accuracy of 1°C.

D2 PROCEDURE

D2.1 Pass hot water through the assembly (as full as possible).

D2.2 Allow the temperature of the water at the outlet of the test assembly to stabilise at 70 – 75°C.

D2.3 Continue to pass water at 70 – 75°C through the test assembly for at least 24 hours.

D2.4 Stop the flow of water and allow the assembly to cool for at least 15 minutes. Fill the test assembly with cold water and test as described in C2 to C6 inclusive.

D3 REPORT

As C9.

